

# GENTHERM

Technology to the next degree™



## 2024 Baird Global Consumer, Technology & Services Conference

**Phil Eyler**, President and CEO

**Matteo Anversa**, Executive Vice President of Finance, Chief  
Financial Officer and Treasurer

Gentherm, Inc. | June 6, 2024

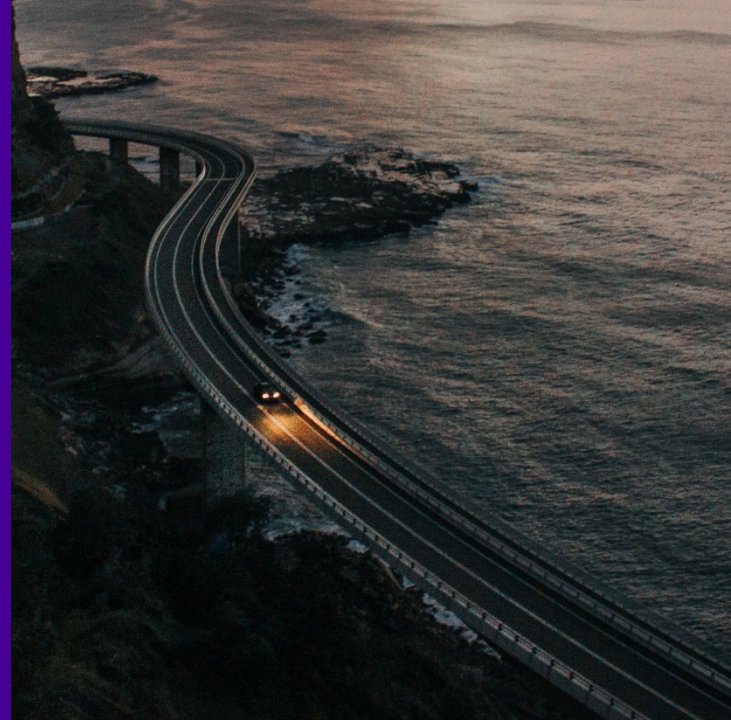
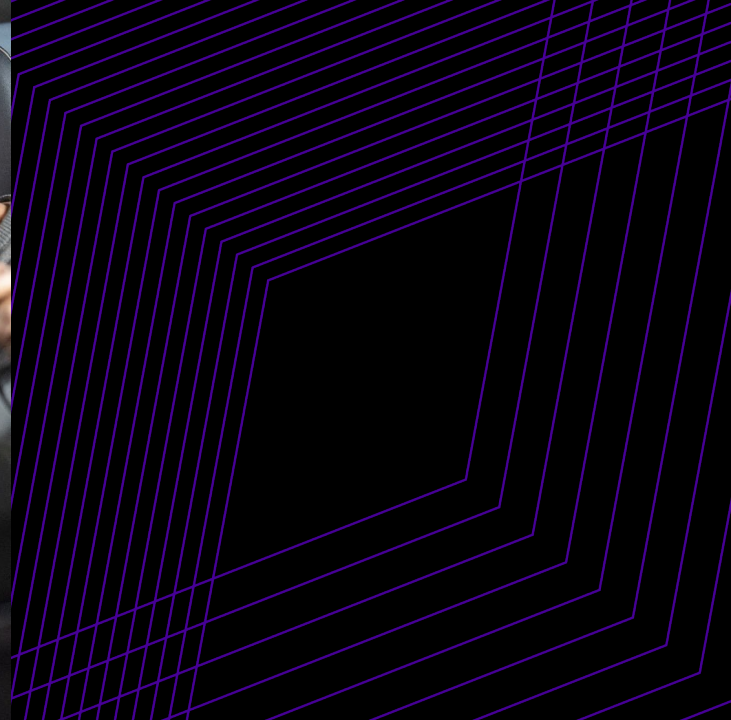

# Use of Non-GAAP Financial Measures\*

In addition to the results reported herein in accordance with GAAP, the Company has provided here or may discuss on the related conference call adjusted earnings before interest, taxes, depreciation and amortization (“Adjusted EBITDA”), Adjusted EBITDA margin, adjusted earnings per share (“Adjusted earnings per share” or “Adjusted EPS”), free cash flow, Net Debt, revenue excluding foreign currency translation, Automotive revenue excluding the impact of non-automotive electronics, one-time benefits from recoveries and retrofits and foreign currency translation, Climate and Comfort revenue excluding the impact of one-time benefits from recoveries and retrofits and foreign currency translation, adjusted operating expenses, each a non-GAAP financial measure. See the Company’s earnings release dated April 30, 2024, for the definitions of each non-GAAP financial measure, information regarding why the Company utilizes such non-GAAP measures as supplemental measures of performance or liquidity, and their limitations, and for certain reconciliations of GAAP to non-GAAP historical financial measures.

\* See Appendix for certain reconciliations of GAAP to non-GAAP historical financial measures.



# Forward-Looking Statement

Except for historical information contained herein, statements in this presentation are forward-looking statements that are made by Gentherm Incorporated (the “Company”) pursuant to the safe harbor provisions of the Private Securities Litigation Reform Act of 1995. All statements that address future operating, financial or business performance or strategies or expectations are forward-looking statements. The forward-looking statements included in this presentation are made as of the date specified herein and are based on management's reasonable expectations and beliefs. In making these statements we rely on assumptions and analysis based on our experience and perception of historical trends, current conditions and expected future developments, as well as other factors we consider appropriate under the circumstances. Except as required by law, the Company expressly disclaims any obligation or undertaking to update any forward-looking statements to reflect any change in its strategies or expectations with regard thereto or any change in events, conditions or circumstances on which any such statements are based. The forward-looking statements are subject to a number of important assumptions, risks, uncertainties and other factors that may cause actual results or performance to differ materially from that expressed or implied by such statements. For a discussion of these risks and uncertainties and other factors, please see the Company’s most recent Annual Report on Form 10-K and subsequent filings with the Securities and Exchange Commission, including “Risk Factors.” In addition, the business outlook discussed in this presentation does not include the potential impact of any business combinations, acquisitions, divestitures, strategic investments and other significant transactions that may be completed after the date hereof, each of which may present material risks to the Company’s future business and financial results.

# Why Gentherm



Pure play leader in thermal management and pneumatic comfort



Global automotive market is large with rapidly growing penetration of thermal and pneumatic solutions



Unique, innovative, energy efficient and software driven solutions key to vehicles of the future



Consistent execution against strategic plan with financial discipline

Poised for high-return growth and outpacing the market



# Winning at Record Pace

✓ Expanding core thermal



CCS<sup>®</sup> expanding in each region, including fast growing domestic Chinese OEMs; significant growth in hands-on-detection enabled steering wheel heaters

✓ Growing market share in pneumatic



Won conquest pneumatic lumbar and massage awards with 9 OEMs globally leveraging the Alfmeier acquisition

✓ Leading supplier of combined systems

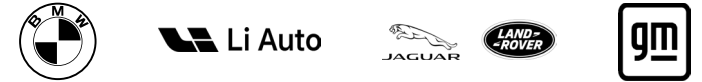

Won customer programs with combined thermal and pneumatic lumbar / massage solutions

✓ Increasing vehicle content



Leveraging ClimateSense<sup>®</sup> and WellSense<sup>™</sup> to increase vehicle content, demonstrated by new business wins

✓ Differentiating with software



ClimateSense<sup>®</sup> software enabling software defined vehicles

Independent partnership model leading to record wins and deeper customer relationships

# Expansive Climate and Comfort Awards

GENTHERM

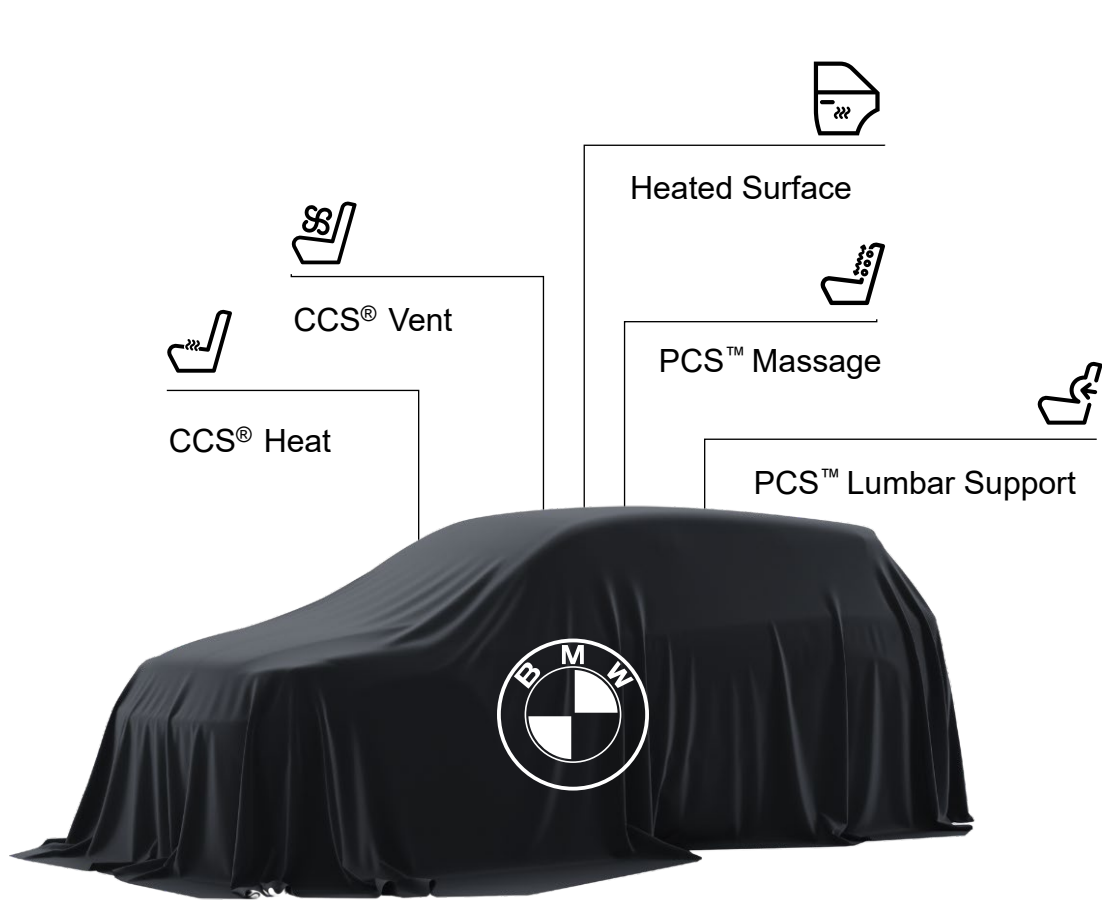

**BMW:** X Series SUVs including: X5 · X6 · X7 · iX5 · iX6 · iX7

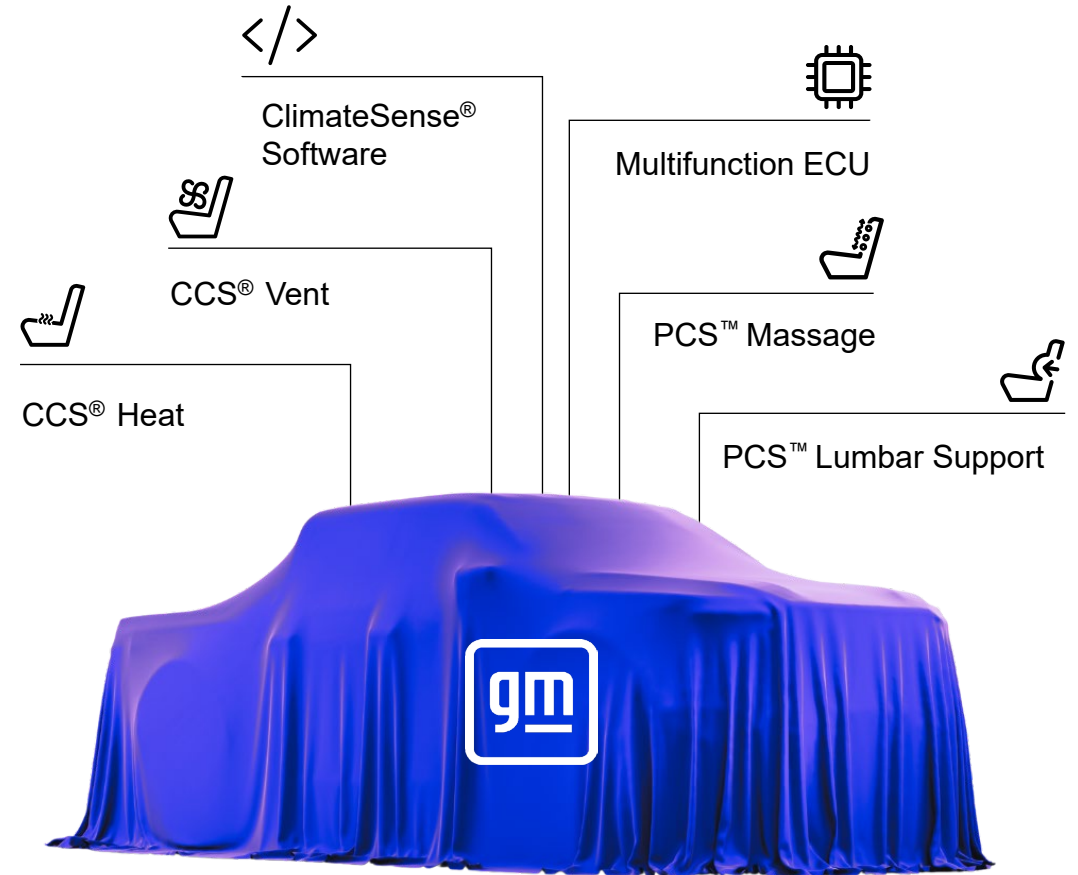

**General Motors:** Truck platform including Chevrolet Silverado & GMC Sierra

Significant content across flagship platforms

# First Puls.A™ Massage Award



---

✓ Combines massage with frequency pulsation

---

✓ Works deeper into muscles at light physical contact

---

✓ Modular system allows for customization

---

✓ Supports relaxation, pain relief and counteracts poor posture

---

✓ Lateral and horizontal impact across the back

---

✓ Makes the ride a unique wellness experience

---

✓ Recharging and energizing effect for all occupants

---

Industry's first proprietary pulsating pneumatic massage solution, continuing trajectory of content growth

# Industry Leading Innovations

**GENTHERM**

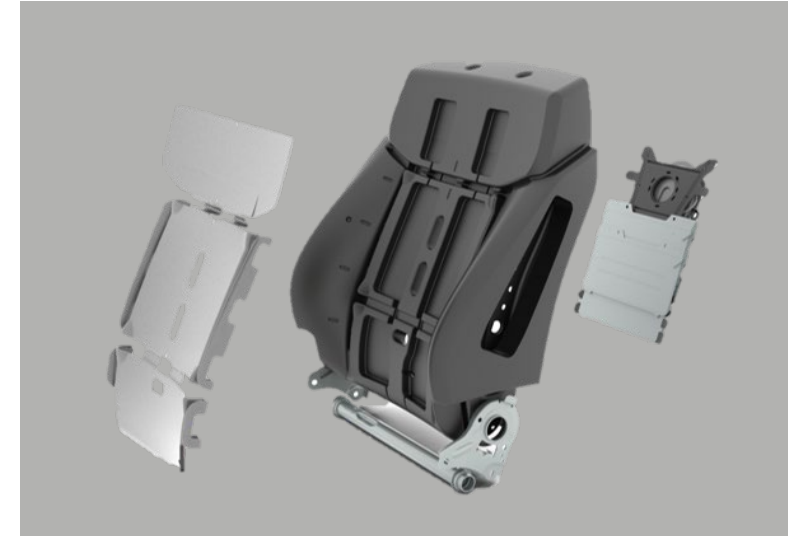
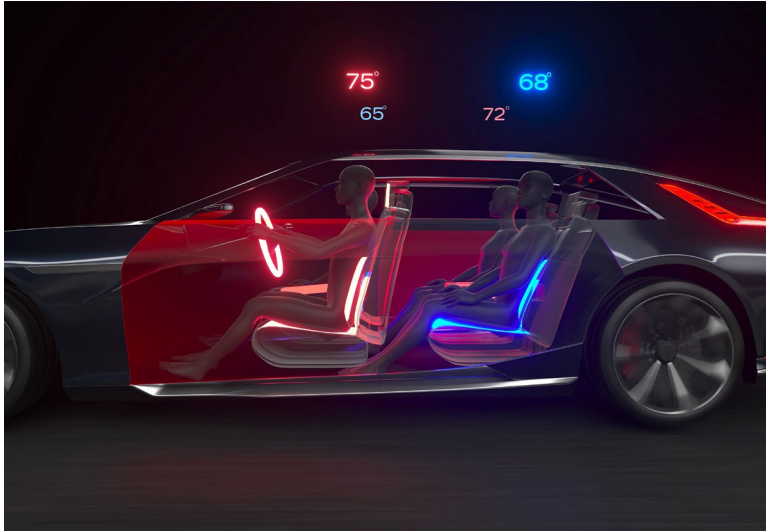

## ClimateSense®

- Best-in-class software controlled thermal comfort
- Enhances energy efficiency and vehicle range
- Personalized microclimate

## WellSense™

- Combines thermal, lumbar and massage
- Proprietary software driven wellness and alertness features
- Enabling software defined vehicles

## ComfortScale™

- Modular and scalable hardware
- Easy to integrate across OEMs and Tier 1s
- Enhanced cost efficiency

Increasing content per vehicle with differentiated and proprietary solutions; well positioned to capitalize on the software defined vehicles of the future



# Why Gentherm



Pure play leader in thermal management and pneumatic comfort



Global automotive market is large with rapidly growing penetration of thermal and pneumatic solutions



Unique, innovative, energy efficient and software driven solutions key to vehicles of the future



Consistent execution against strategic plan with financial discipline

Poised for high-return growth and outpacing the market